

## ud-800

### Washer Combination for Water Based Paint or Solvent



#### Operating Manual and Test Log Book for Spray Gun Cleaning System ud-800

– Translation of German Original Document –

**EU Declaration of Conformity according to DIN EN ISO/IEC 17050-1**

Manufacturer: B-TEC GmbH  
Zunftweg 6-8  
31303 Burgdorf / Ehlershausen  
Germany



Herewith, we declare that the machines and marketed models described in the following conform in conception and in design to the relevant fundamental safety and health requirements of the applicable directives. This object of conformity is issued under the sole responsibility of the manufacturer. The object of the declaration is in conformity with the relevant Union harmonisation legislation.

If you modify the machine without our explicit agreement, this declaration will be invalidated.

Product type: Spray gun cleaning system

Type designation: **ud-800**

Serial number: \_\_\_\_\_

Date of construction (month/year): \_\_\_\_\_

This machine has been designed in accordance with the following regulations:

Machine directive **2006/42/EC**

ATEX directive **2014/34/EU**

ATEX description:  II 2G Ex h IIB T6 Gb

Registered with: PTB 0102 / R.No.: 05 ATEX D 116

The following harmonised technical standards have been applied:

Safety of machinery: **DIN EN ISO 12100**

Machines for surface cleaning and pre-treatment of industrial items using liquids or vapours

- Part 1: Common safety requirements: **DIN EN 12921-1**

- Part 2: Safety of machines using water based cleaning liquids: **DIN EN 12921-2**

- Part 3: Safety of machines using flammable cleaning liquids: **DIN EN 12921-3**

Explosive atmospheres: Non-electrical equipment for explosive atmospheres

- Part 36: Basic method and requirements: **EN ISO 80079-36**

- Part 37: Protection constructional safety "c": **EN ISO 80079-37**

Pneumatic fluid power - General rules and safety requirements for systems and their components:

**DIN EN ISO 4414**

Responsibility for technical documents: Michael Bellroth, Christian Bellroth

Address: Refer to manufacturer's address

Hannover, 02.01.2020

Place/Date/Manufacturer's signature:

Job title of signatory: Managing director

## Table of Contents

1.	Important Information .....	1
1.1.	Explanation of the Symbols .....	1
1.2.	Operating Instruction .....	1
1.3.	Liability and Warranty .....	1
1.4.	Intended Use .....	2
1.5.	Requirements to be the Operator .....	2
2.	Safety Requirements .....	3
2.1.	General Safety .....	3
2.2.	Operational Safety .....	3
2.3.	Hazards from Pneumatic Energy .....	5
2.4.	Suggestions for Operating Instructions .....	5
3.	Approved Cleaning Agents .....	6
4.	Technical Description of the Machine .....	7
4.1.	Technical Data .....	8
4.2.	Spare Part Names .....	9
4.3.	Pneumatic Diagram .....	10
4.4.	Spare Parts Ordering Numbers and Accessories .....	11
5.	Zone and Machine Classification according to ATEX .....	12
6.	Requirements for the Installation Site .....	12
7.	Transport and Installation .....	13
7.1.	Exhaust Ducting .....	13
7.2.	Compressed Air Connection .....	14
7.3.	Grounding / Earthing .....	14
8.	Commissioning .....	15
8.1.	Containers for Cleaning Fluid .....	15
8.2.	Positioning of Containers and Hose Allocation .....	15
9.	Working with the Machine .....	16
9.1.	Operational Procedure .....	16
9.2.	Adjusting Options .....	18
10.	Care and Maintenance .....	19
11.	Disposal .....	19
12.	Troubleshooting .....	20
13.	Safety Inspection Checklist .....	21

## 1. Important Information

Thank you for the trust you placed in us by purchasing this B-TEC product. On the machines type plate you find the exact type designation and serial number to ensure good service and shipment of spare parts. The cleaners have been designed and manufactured to the highest quality standards for best operational safety.



**Read this document carefully before putting the machine into operation and keep it for future reference.**

On page 21 of this manual, there is a form for documenting the safety inspections to be carried out at regular intervals. The form has to be filled in by specialist technicians (persons with sufficient knowledge and experience or manufacturer's technicians) or experts (e.g. engineers or Technical Control Board experts).



**A safety inspection must be carried out before commissioning and at least once a year.**

B-TEC machines are to be used solely in accordance with the intended use. Usage not in accordance with the intended use as well as unauthorised modifications invalidate the liability of the manufacturer for any damages resulting from this. Detailed information regarding intended use as well as liability and warranty can be read in section 1.3 and 1.4.



**The B-TEC machines are only to be used according to the intended used. Improper use of the machine can endanger the health of the operator.**

### 1.1. Explanation of the Symbols

To directly draw attention to important information in this operating manual, the symbols "Caution!" and "Notice!" are used. Please note that paragraphs with these symbols need particular attention.

#### Caution!



You will see this symbol whenever attention is drawn to situations in which danger to life can arise due to or during incorrect or improper operation. Pay special attention to these symbols and act carefully.

#### Notice!



You will see this symbol in the operating manual whenever your attention is being drawn to correct work procedures, economic ways of operating or when the machines may be damaged by incorrect operation.

### 1.2. Operating Instruction

The responsible person within the company where the machine is placed has to create operating instructions in accordance with the "Occupational Safety and Health Regulations" applicable in the respective country. The operating instructions must be adapted to the cleaning fluid used and country of application.

### 1.3. Liability and Warranty

The cleaning machine is state of the art, tested and operationally safe. Liability for the function of the machine is transferred to the operating company, if the machine is improperly maintained or repaired by persons who are not authorised by the manufacturer and / or supplier, or if it's used against the

intended use and the instructions of the user manual. The operator is obliged to operate the machine only when in immaculate condition. The manufacturer is liable for errors or omissions - to the exclusion of further claims - only within the scope of the statutory warranty obligations. We reserve the right to make technical changes any time for continuous development and improvement of our products. Such changes, mistakes and misprints do not constitute a claim for damages. Only original spare parts and accessories are to be used. The manufacturer and / or supplier is not responsible for damages caused by ignoring the instructions in this operating manual. Warranty and liability conditions of the manufacturers and / or supplier sales and delivery terms are not extended by the above notes.

B-TEC warrants its products to be free from defects in materials and workmanship, for a period of 24 months on a one shift basis. In case of exceptional usage such as multiple-shift operation, the statutory warranty is shortened to 12 months (two-shift operation) or 8 months (three-shift operation). The period starts from the date the machine is shipped from the factory. The guarantee expires prematurely if the customer or a third party undertakes inappropriate modifications or repairs or if the customer, in case of a defect, does not immediately take all appropriate steps to mitigate the damage and give the supplier the possibility of remedying such defect.

#### 1.4. Intended Use



**This spray gun cleaning system may only be used for its intended purpose. It is not intended for other purposes than the following terms. The manufacturer/supplier is not liable for any damages resulting from improper use.**

The intended use of this machine is to clean spray guns or paint-soiled parts/tools (e.g. stirring rods, mixing bowls etc.).

The machine can be used with the following cleaning agents (For details see section 3):

- Solvents (GHS categories 2 and 3).
- Non-combustible, water-based cleaning fluids for water soluble paints.

Cleaning agents containing more than 65% of acetone are not permitted.

This machine is for commercial use only, but not for continuous operation (e.g. serial production).

This machine is classified as equipment group II, equipment category 2G, type of protection Ex h, eligible for gases of explosion group IIB, equipment protection level Gb and can be used in zone 1.

See also type plate:  II 2G Ex h IIB T6 Gb

Improper use of the machine can endanger the health of the operator and of others and cause damage to the cleaner itself or to other objects. Any other use of the machine must be agreed and approved with the manufacturer in advance.

#### 1.5. Requirements to be the Operator

The machine may only be used by competent personnel who, by virtue of their training, knowledge or experience, ensure proper handling and are aware of the dangers (for example, by reading the operating manual).

## 2. Safety Requirements

### 2.1. General Safety

The machine is built according to the state of the technology and can be operated safely. However, this does not mean that the consequences of all operational failures are protected by technical measures. Dangers can arise from this machine if it is used improperly or incorrectly. However, additional organisational measures have to be taken into account for certain workflows, such as the removal of residual paint from the gun.

- Read and follow the operating instructions for machine as well as the safety instructions before commissioning.
- Always keep the manual available in the immediate vicinity of the machine.
- The machine may only be operated by trained personnel. Operators under the age of 18 are only allowed to operate the machine when under supervision of an expert.



For some users, hazard assessment activity restrictions may result, e.g. for persons with chronic respiratory problems or allergic diseases as well as for pregnant women or nursing mothers.



For the correct operation of the machine, the safety and operating instructions are valid in all cases. These must be read carefully and followed strictly!

The manufacturer recommends to strictly follow the occupational safety provisions, rules and information applicable in the respective country for using spray gun and part cleaning systems such as the following examples: "Accident prevention - Principles and prevention", "Safety and health protection warnings at the workplace", "Safety rules for air pollution control systems for the workplace", "Safe use of the machine by following operating instructions", "Safe use of the machine by following operating instructions", "Avoidance of ignition from electrostatic charges", "Guidelines for facilities for cleaning parts with solvents", "Use of protective clothing", "Use of eye and face protection", "Use of protective gloves", "Industrial Safety".

### 2.2. Operational Safety

 **Follow the information and warning signs attached to the machine.**

- The machine may only be operated, if:
  - the integrated suction machine (Venturi system with flexible exhaust hose) is connected and the resultant (solvent-) fumes are safely discharged to the outside in the free air in order to avoid fire, explosion and health hazards. See section 7.1.
  - grounding / earthing is ensured using a grounding cable (potential equalisation)! Connection must be carried out by a specialist. See section 7.3.
- In all cases, the local safety and accident prevention rules for the use of the machine must be followed.
- Fire, naked flame and smoking prohibited.

- Open fires and other sources of ignition (e.g. due to grinding or welding, any flying sparks) are not allowed within a radius of 1 metre around the machine. This applies also e.g. for lighting and fans as well as the associated electrical components. 
- Depending on the cleaning application, use the required personal protective and chemical resistant protective equipment. The minimum required protective equipment is eye protection and gloves. Optionally protective clothing and safety shoes are recommended.

Minimal requirement:



Optional:



- Ensure that clothing (especially footwear) is conductive.
- Do not place the protective equipment on the machine.
- If clothing has been wetted with solvent / cleaning fluid, smoking is also prohibited outside the Ex-zone. Take off the contaminated clothing immediately. There is risk of skin irritation, allergies, etc. Persons wearing contaminated clothing must not be exposed to sources of ignition (e.g. welding). Risk of fire.
- In the event of a fire, immediately stop the compressed air supply and close the door of the machine.
- Compliance with country-specific workplace exposure limits legislation according to safety data sheets must be documented.
- The limit values of the country specific air pollution and adherence thereto must be observed.
- If the machine is not used, the door must always be closed for safety reasons.
- The operator has to ensure that nobody else is in the working area of the machine.
- Use only permitted solvents / cleaning fluids (section 3). These must be free of Halogenated hydrocarbons (CKW, CFC, TRI, PER, etc.).
- If water (e.g. with additives) is used as a cleaning fluid, this must not be discharged into the sewer system.
- Pay attention to the safety data sheet of the cleaning fluid.
- Do not eat or drink near the machine. Clean your hands before eating any food or drink after working. Danger of poisoning!
- Avoid inhalation of fumes and contact with the solvent / cleaning fluids. Risk of respiratory tract irritation!
- Do not add any other liquids to the cleaning fluid, such as kerosene, gasoline, chlorinated hydrocarbons, acids, alkalis, pickling agent or brake cleaner.
- Do not overfill the unit with cleaning fluid, as this may lead to an overflow of the barrel.
- Immediately collect spilled solvent(s) with suitable binders and dispose them in accordance with regulations. The water resources legislation must be complied with.
- When changing the cleaning fluid, all applicable regulations (e.g. waste water regulations) must be observed!



**It is prohibited to open the pump casing in the machine. The manufacturer is not liable for any damage and/or secondary/subsequent damage caused by opening the pump casing on purpose or negligent opening. If you have any problems with your pump, please contact your distributor or the manufacturer's support service.**

### **2.3. Hazards from Pneumatic Energy**

Only specialists with expert knowledge and experience may work on pneumatic machines. When working on pneumatic systems, these must be disconnected from the air supply and de-pressurised in order to prevent injury.

### **2.4. Suggestions for Operating Instructions**

Operating instructions are regulations that a company creates for safe working for its employees. These are binding instructions issued by the company in line with its policy and the law. Employees are obligated to follow these instructions.

The employer is responsible for creating and publishing workplace related operating procedures e.g. regarding Occupational Safety and Health Regulations, the Water Resources Legislation and, where applicable, the Control of Hazardous Substances applicable in the relevant country. These operating instructions are therefore to be complemented by national regulations on accident prevention and environmental protection.

#### **Give your employee e.g. the following information:**

- The hazards involving the handling of contaminated parts and the solvents used, the necessary protective measures and guidelines, including instructions in case of danger and first aid.
- The type and scope of periodic inspection for the safe working condition of the machine.
- Environmental Protection.
- Safe operation of the pneumatic system.
- Clean and safe working environment.
- The responsibility for operation must be clearly regulated by the company and must be complied with by all persons designated to operate the machine. Under no circumstances should unauthorised or untrained persons use the machine.
- The operator has to operate the cleaning machine only in perfect condition and has to notify their supervisor immediately in case of any changes affecting safety and environmental protection.
- Follow all warnings and warning signs.

### 3. Approved Cleaning Agents

Only use solvents / cleaning fluids that meet the following specifications:

- Highly flammable liquids (category 2, flam. liq. 2):
  - GHS/CLP H225, flash point <23°C, boiling point >35°C.
  - Formerly according to 67/548/EWG: R11, Hazard symbol „F“.
- Flammable liquids (category 3, flam. liq. 3):
  - GHS/CLP H226, flash point 23°C - 60°C.
  - Formerly according to 67/548/EWG: R10, no Hazard symbol.
- Non-combustible, aqueous cleaning agents (neutral or slightly alkaline pH) such as B-TEC H<sub>2</sub>O Cleaner for water-soluble paints.

If using flammable cleaning liquids, ensure at least a medium electrical conductivity of the liquid. Usually solvents are mixtures of liquids with high and low conductivity and therefore are sufficiently conductive. If you have any doubts, ask your supplier.



It's recommended to use purified water to mix B-TEC H<sub>2</sub>O-RK cleaner, if tap water is extremely hard water or contains high quantities of iron.



Ensure that the used cleaning fluid is suitable and does not attack the surface of the object to be cleaned. Suitability shall be ensured by the operator in preliminary tests. The manufacturer and / or supplier does not assume any liability for damages caused by these tests.



Acids are not permitted. Paint strippers or other additives (e.g. brake cleaners etc.) must not be used in the machine.



Safety data sheets relevant to the products supplied should always be available on the premises. These will contain the information about the cleaning agents that you are using.



Never alternate the use of solvents and cleaning fluids (for water-based paints) in the same machine as this will damage it and void the warranty. Follow the manufacturer's instructions at all times. Alternating the two types of cleaning agents can cause gas build up and explosions!



When changing from solvents to cleaning fluids for water-based paints (or vice-versa) the paint gun cleaner must be completely cleaned of paint, water and fluid residues.

Recommendation to reduce solvent consumption:



If the machine is connected to a continuously running exhaust system and you're using solvent, we recommend the pneumatic exhaust solvent saver to reduce solvent consumption.

See B-TEC catalogue number:

- Pneumatic exhaust solvent saver diameter 125 mm art.-no.: 10000348

#### 4. Technical Description of the Machine

The ud-800 is a cleaning system for automatically cleaning spray paint guns. The automatic cleaning cycle is activated by a timer. In addition, there is a brush and a clean rinse nozzle in the cleaning chamber for cleaning objects or spray guns manually.

Furthermore the machine has a blow-off gun for drying and blowing out cleaned spray paint guns. The machine has a strong exhaust suction system that switches on and off automatically as soon as the machine's door is opened or closed. The machine is operated exclusively by pneumatic parts.

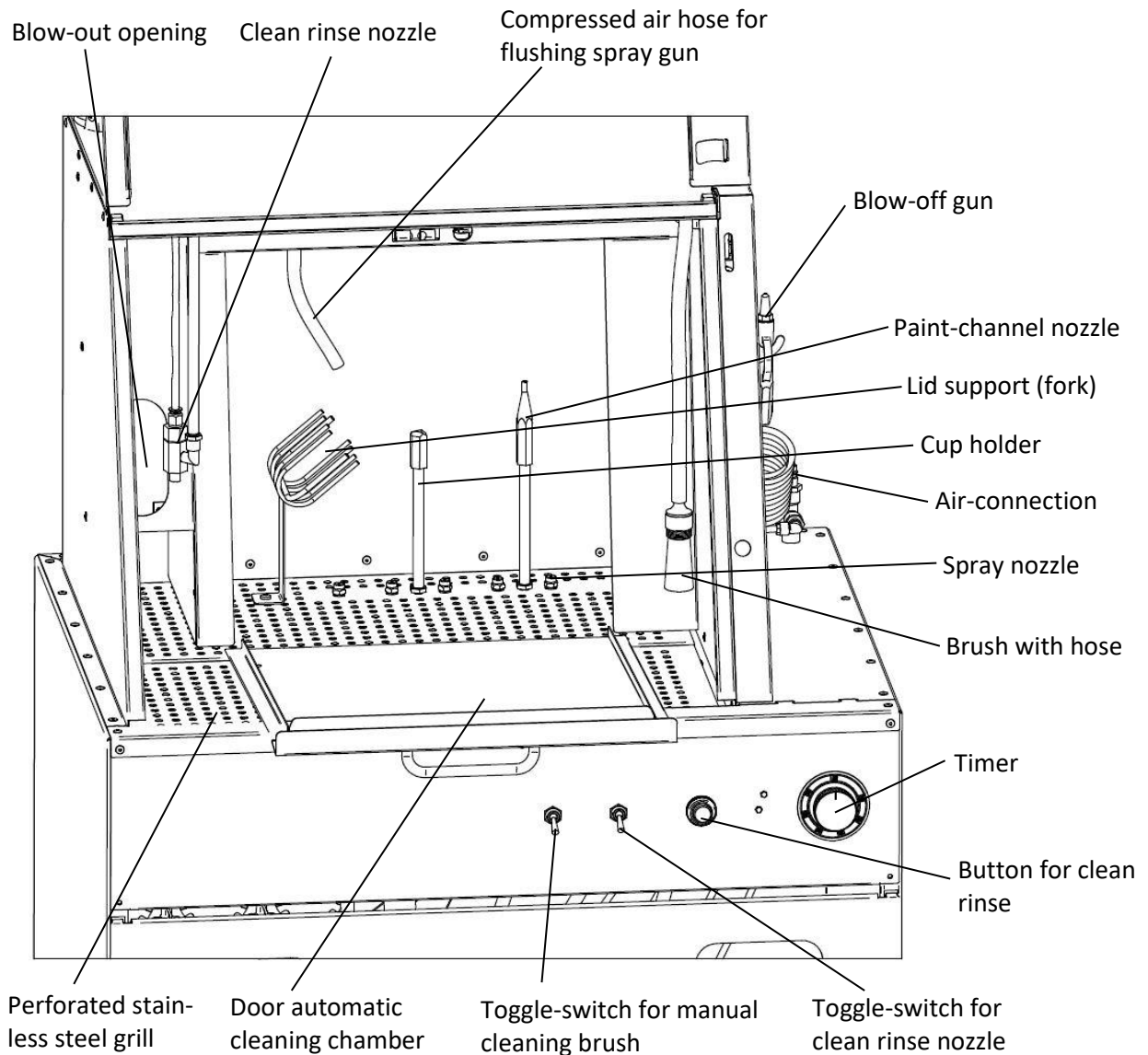

Figure 4-1

- Technical changes and errors reserved. All pictures similar -

#### 4.1. Technical Data

##### Compressed air connection

Operating pressure: max. 6 bar  
 Compressed air demand: 240 l/min

##### Acoustic emission

Average level of acoustic emission: 78 dB(A)

##### Exhaust air flow rate

Total at 0.2 m/s: 213 m<sup>3</sup>/h

##### Machine dimensions (per side)

Machine outside (Width × Height × Depth): 750 × 1750 × 600 [mm]  
 Washing chamber total (W × H × D): 570 × 450 × 520 [mm]  
 Washing chamber autom. cleaning (W × H × D): 470 × 355 × 220 [mm]

##### Size of the container below the cleaning machine

1 × container for circulating fluid. Container size max. 60 litres.  
 1 × container for fresh fluid. Container size max. 30 litres.

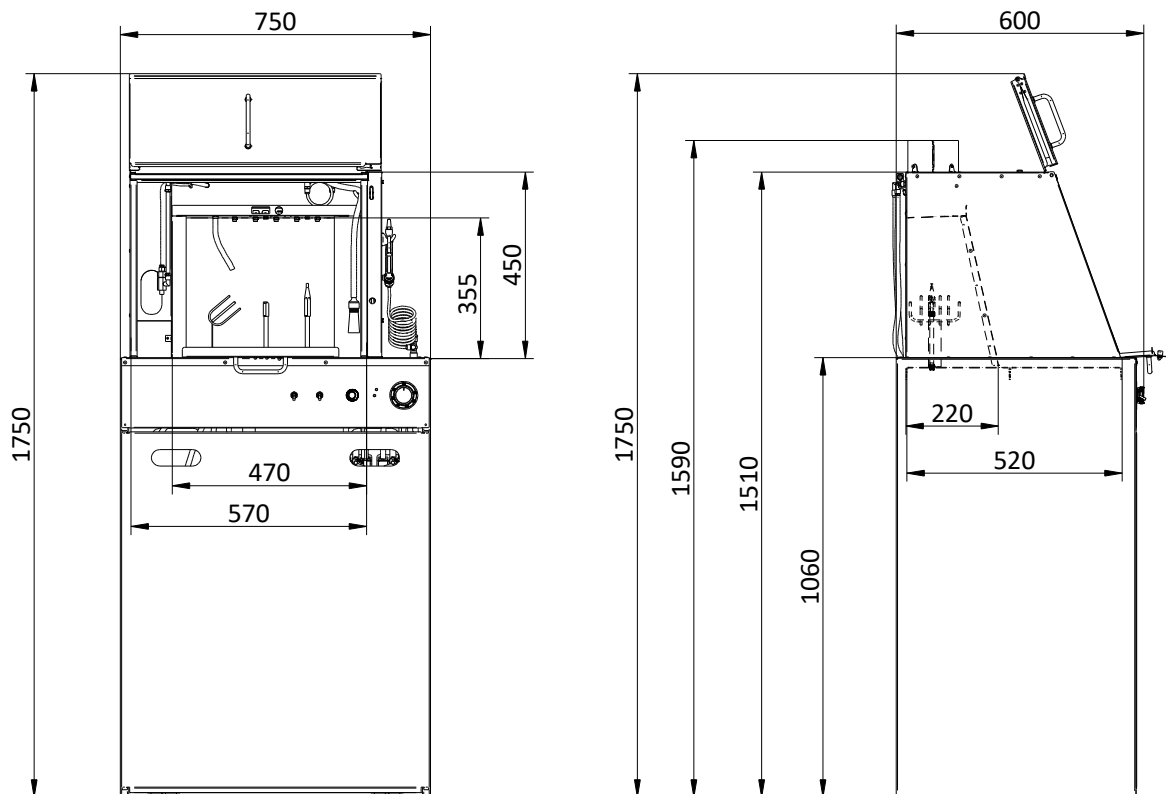

Figure 4-2

- Technical changes and errors reserved. All pictures similar -

## 4.2. Spare Part Names

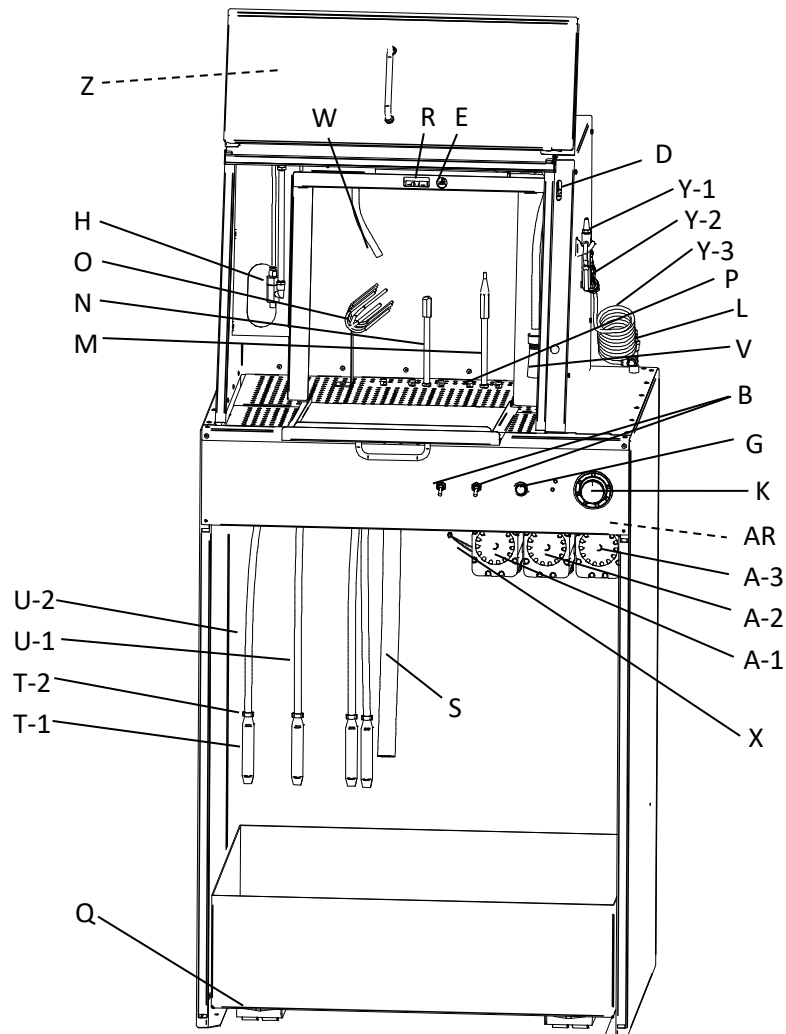

Figure 4-3

A-1	- Pump for manual cleaning brush	Q	- Transport rolls for roller bund
A-2	- Pump for automatic cleaning cycle	R	- Double ball catch
A-3	- Pump for clean rinse	S	- Draining hose
AR	- Check-valve	T-1	- Intake strainer
B	- Toggle switch	T-2	- Strainer one ear clamp
D	- Roller valve for activation	U-1	- Corrugated hose, transparent
E	- Roller valve for inside door or timer	U-2	- Corrugated hose, grey
G	- Button clean rinse	V	- Brush with hose
H	- Clean rinse nozzle	W	- Hose for air flushing
K	- Timer	X	- Grounding cable
L	- Compressed air connection plug	Y-1	- Blow-off gun with short tube
M	- Paint channel nozzle	Y-2	- Brass connection socket
N	- Cup holder	Y-3	- Coil hose
O	- Lid support (fork)	Z	- Exhaust hose alu 125 mm
P	- Spray nozzle		

- Technical changes and errors reserved. All pictures similar -

**4.3. Pneumatic Diagram**

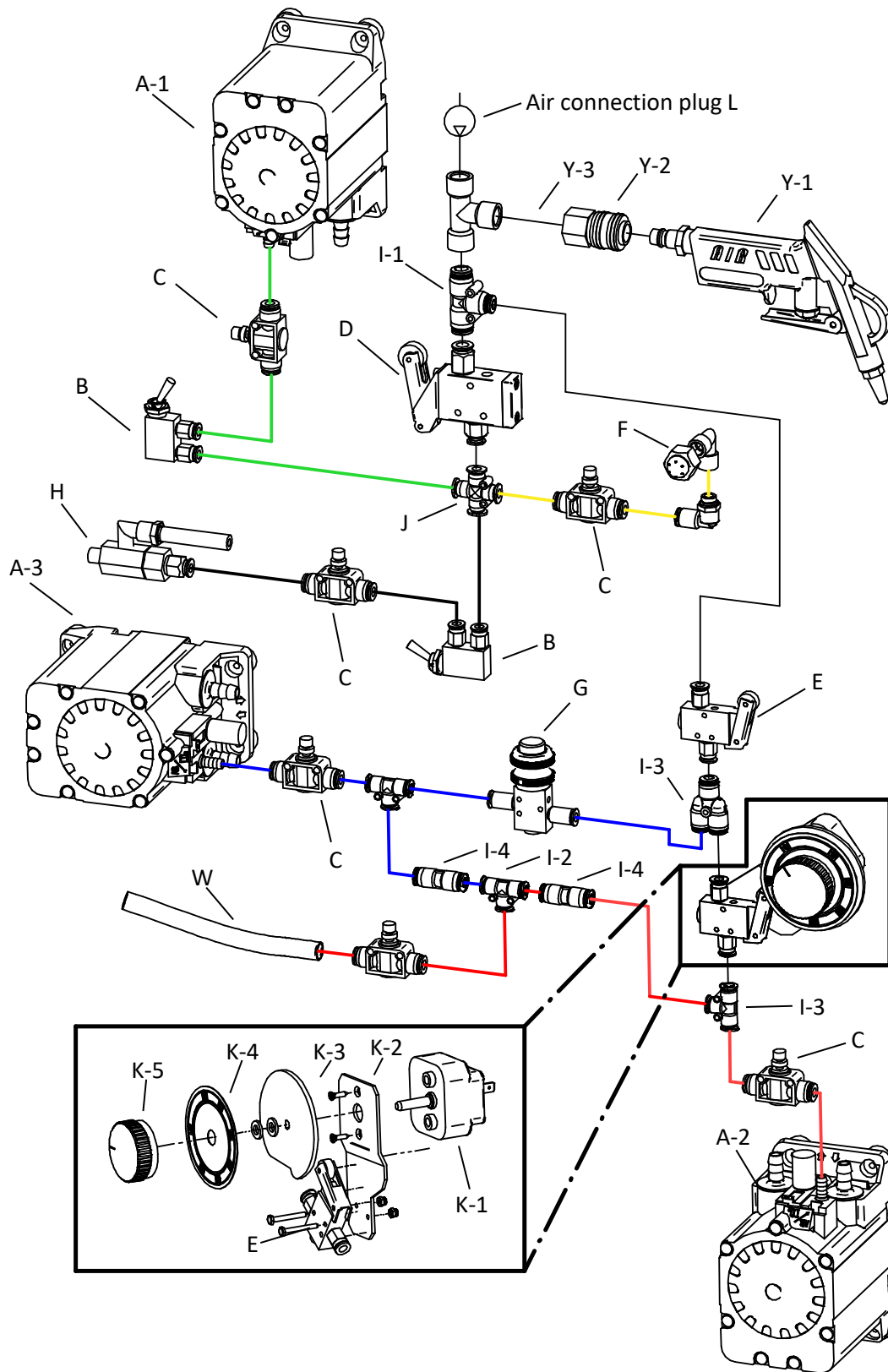

Figure 4-4

- Technical changes and errors reserved. All pictures similar -

#### 4.4. Spare Parts Ordering Numbers and Accessories

A	- Main Pump ¼"	10000554
	- Connector for pump ¼", incl. O-ring (included in art.-no. 10000554)	10000561
AR	- Check-valve, inner thread, G 1/4" EPDM	10001069
B	- Toggle-switch	10000589
C	- Flow adjuster	10000582
D	- Roller valve for activation	10000620
E	- Roller valve for inside door or timer	10000579
F	- Air suction nozzle	10000415
G	- Button for automatic clean rinse, completely assembled	10000414
H	- Clean rinse nozzle complete with pipe and connection	10001116
I-1	- T-plug connector 2 x 8 mm, 1 x 6 mm	10000847
I-2	- T-plug connector 6 mm	10000845
I-3	- Y-plug connector 6 mm	10000896
I-4	- Connector 6mm with check-valve function	10001371
J	- Cross connector 6 mm	10000893
K	- Timer complete (Time-limit switch, timer knob and scale)	10000416
K-1	- Timer – Time limit switch 6 min	10000444
K-2	- Timer – Fixing plate	10000327
K-3	- Timer – Switching disk	10000328
K-4	- Timer – Scale for timer 0 – 6 min	10000445
K-5	- Timer – Timer knob	10000443
L	- Compressed air connection plug	10000908
M	- Paint channel nozzle complete with pipe	10000420
N	- Cup holder complete	10000418
O	- Lid support (fork)	10000439
P	- Spray nozzle	10000429
Q	- Transport rolls unit consist out of 8 rolls	10000462
R	- Double ball catch	10000467
S	- Corrugated hose for draining	10000658
T-1	- Strainer, stainless steel	10000473
T-2	- Strainer one ear clamp	10000649
U-1	- Corrugated hose, transparent	10000656
U-2	- Corrugated hose, grey	10000655
V	- Brush with hose	10000417
W	- Corrugated hose for air flushing, black	10000657
X	- Grounding / earthing cable	10000958
Y-1	- Blow-off gun with short tube	10000446
Y-2	- Brass connection socket 1/4" interior 7.2	10000610
Y-3	- Coil hose 1m with Connectors angle and straight + double nipple	10000645
Z	- Exhaust hose aluminium 125 mm	10000644
Accessories	Trigger clamp standard, stainless steel	10000436
	Pneumatic exhaust solvent saver, ATEX - 125 mm	10000348
	H <sub>2</sub> O-Cleaner-RK, water based paint cleaner concentrate, 10 L	10000633
	Plastic container 30,0 L with cap, non-conducting	10000711
	Plastic container 30,0 L with cap, conducting	10000691
	Plastic container 60,0 L with cap, conducting	10000767
	Pressure reducer with manometer 1/8" incl air connector	10000619

## 5. Zone and Machine Classification according to ATEX

This machine is classified as equipment group II, equipment category 2G, type of protection Ex h, eligible for gases of explosion group IIB, equipment protection level Gb and can be used in zone 1.

See also type plate:  II 2G Ex h IIB T6 Gb

In accordance with legal requirements, the ATEX zone definition around the machine and creation of an explosion protection document comes under the responsibility of the "responsible person of the company" where the machine is placed as this classification is subject to the cleaning fluid used and various conditions such as ventilation.

However, at this point the operator should be supported with general advice to comply with this obligation. Helpful advice can also be found in EN 12921-1 and -3 and EN ISO 80079-36.

If using the machine with flammable cleaning fluids, the following zone designation has to be considered:

**Zone 1** → The interior of the machine

**Zone 2** → Surroundings within 1.0 m

Mark the different zones with appropriate warning and prohibition signs. Markings on the floor can be helpful. In the area surrounding the machine, open flames and other ignition sources (e.g. welding or grinding equipment) are not allowed. In addition, smoking is prohibited. Temporary work causing ignition sources must be approved in writing and appropriate additional safety measures must be applied (e.g. remove all combustible materials; firefighting equipment must be on hand in the working area.)

## 6. Requirements for the Installation Site

- Horizontal industrial floor with electrical resistance of max.  $10^8$  Ohm.
- Dry and protected from frost.
- Very good technical room ventilation with at least 5 air changes per hour (Depending on local regulations).

**Requirement in German DGUV (German Social Accident Insurance) Information 209-046:**

*"In rooms with filling, mixing and pumping of flammable liquids you must have at least 5 air changes per hour. Therefore, a technical room ventilation system is required. The air-outlet opening must be near the ground. Air-inlet and -outlet must be placed in a way that a complete and even air exchange is achieved"*

- Do not install or operate the machine within a radius of 1.5 m from heat sources.
- Ensure an ambient temperature of 5 °C – 40 °C and do not expose the machine to direct sunlight, as this carries a risk of overheating.
- Follow the relevant legislative and regulatory safety instructions regarding substances hazardous to water applicable in the country where the machine is installed.
- Follow the safety regulations according to zone designation.
- The machine can be placed against the wall or in a corner. A 1.5 m space should be provided in front of the machine.

## 7. Transport and Installation

The machine is delivered packed. Unpack the machine outside an explosive atmosphere and bring it to the installation site. Install the machine as described in the following sections.

### 7.1. Exhaust Ducting

The exhaust air hose must be integrated in the exhaust system at the installation site and must be routed outdoors properly into the so-called "free air space". Place the exhaust air hose vertically, a minimum of one metre for optimal function of the exhaust system and stretch the hose as far as possible in order to avoid a reduced cross-section. In this way optimal exhaust suction will be achieved.

Ensure that fumes are not directed into areas where people are likely to be. The exhaust air has to be led away safely. That means according to ATEX and especially not into flues serving furnaces or fireplaces and not into the exhaust ducts of spraying and drying cabinets. In case the exhaust system conditions at the installation site require a longer exhaust air hose or the instructions in how to route the exhaust air system cannot be complied with, please contact an ATEX-ventilation system specialist to ensure safe operation. The power of the integrated air suction nozzle is limited to max. ca. 4 metres of ducting, depending on the route of ducts (corners, radii, height). An explosion-proof exhaust fan is required for longer ducting. It's recommended not to connect the machine directly to a rigid pipe. Use at least 30-40 cm of the flexible B-TEC exhaust hose to ensure that the machine can be relocated or repaired conveniently if necessary.

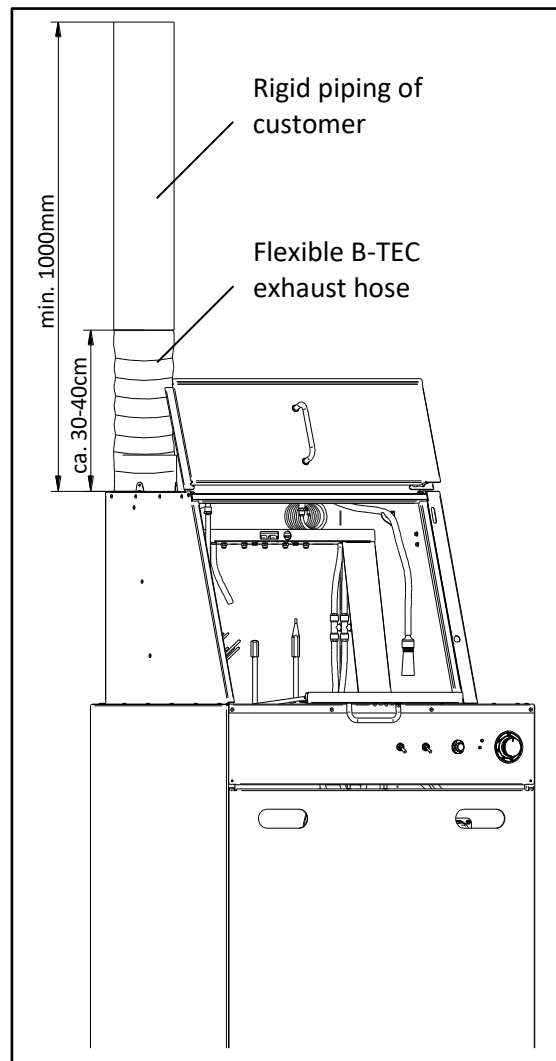
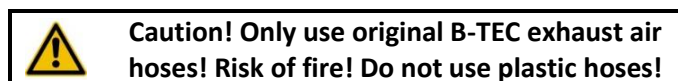

Figure 7-1

Diameter of exhaust hose:  $\varnothing$ 125 mm

**The exhaust air flow rate can be adjusted at the flow adjuster as needed depending on the length of the duct.**



- Technical changes and errors reserved. All pictures similar -

## 7.2. Compressed Air Connection

A compressed air supply is needed for the machine.



**Operating pressure max.: 600 kPa (6 bar , 87 psi)**

**Operating pressure min.: 500 kPa (5 bar , 73 psi)**



A **pressure regulating valve (Item no.: 10000619)** has to be fitted if the compressed air connection exceeds the required operating pressure. Use only **dry and oil-free air!**

**Betriebsdruck max. 6 bar  
trockene und ölfreie Luft einsetzen  
operating pressure max. 6 bar / 87 psi  
dry and oil free air only**

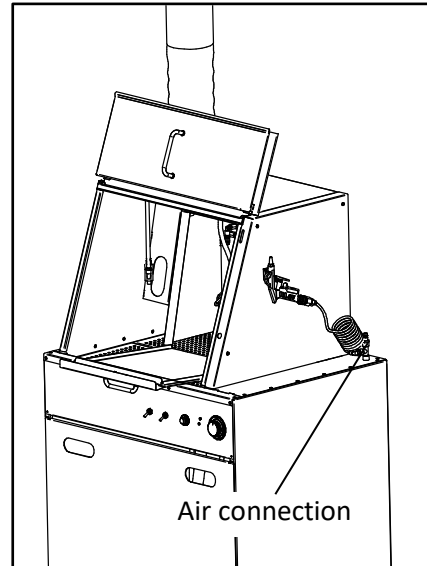

Figure 7-2

## 7.3. Grounding / Earthing



**The machine has a grounding / earthing connection and may not be operated without being grounded!**

The machine has a grounding / earthing cable, which needs to be grounded / earthed safely by a competent person (e.g. electrician). **Customer-provided containers have to be grounded separately!**

After proper installation and mounting of the exhaust hose, connection to the compressed air supply and grounding, the machine can be commissioned.

- Technical changes and errors reserved. All pictures similar -

## 8. Commissioning



Commissioning may be done only after reading and following the operating manual carefully! Commissioning performed without following the operating manual and complying with all applicable regulations can lead to damage to persons, property, or the environment. Wear personal protective clothing. See section 2.2 - Operational Safety).

After proper installation (Section 5 & 6) and mounting of the exhaust hose (Section 7.1), connection to the compressed air supply (Section 7.2) and grounding (7.3), the machine can be commissioned.

### 8.1. Containers for Cleaning Fluid

1 × 60 litre container filled with 30 litres (recirculating fluid) and 1 × 30 litre container filled with 30 litres (fresh fluid). See Figure 8-1. When refilling the fresh fluid, ensure that the container for circulating liquid has a remaining capacity of 30 litres to prevent overflowing of liquid. It is recommended to also renew the circulating liquid when refilling the clean rinse liquid.

### 8.2. Positioning of Containers and Hose Allocation

1. Remove the front cover and place the containers as shown in Figure 8-1.
2. Moisten the draining and intake hoses incl. intake strainer with a wet cloth and insert the moist hoses as follows: Insert the black draining hose (Ø 28 mm) and grey intake hoses into the 60 litre container, which is provided for recirculating cleaning fluid. Insert the transparent hose into the 30 litre container for fresh cleaning fluid.
3. Reinsert the front cover.

The machine is now ready for operation.



Figure 8-1

## 9. Working with the Machine

### 9.1. Operational Procedure

Working with the manual cleaning area of the machine (see also Figure 4-1 & Figure 4-3)

Open the main door. The exhaust suction system starts working automatically.

Activate the pump for the brush with the toggle-switch labelled "**Brush**". The recirculating cleaning fluid from the 60 litre container flows through the brush.

The clean rinse nozzle can be activated by the toggle-switch "**Clean rinse**". Fresh cleaning fluid flows from the 30 litre container.

The output can be adjusted with a flow adjuster (See colour coding on this page or section 9.2).

Colour coding of the hoses for the manual cleaning area:

- Green: Brush
- Black: Clean rinse nozzle

With the blow-off gun you can dry objects or spray guns. You can disconnect the blow-off gun and plug in the cleaned spray gun to blow it out into the blow-off opening.

When the manual cleaning area is no longer required, close the main door. The exhaust suction stops automatically.



**Do not allow the doors to slam shut! All doors must be handled carefully and with caution by the user!**

Working with the automatic cleaning area of the machine (see also Figure 4-1 & Figure 4-3)

Open the main door. The exhaust suction system starts working automatically. Open the door of the automatic cleaning chamber and place the gun as follows (Figure 9-1):

1. Remove the lid of the cup and place it into the lid support fork. Ensure that the paint-soiled inner surface faces downwards towards the interior of the cleaner.
2. Paint spray gun without strainer: Place the gun upside down on the paint channel nozzle **without pulling the trigger**. The cup stays screwed.  
Paint spray gun with strainer: Unscrew the cup and place it upside down on the cup holder. Remove the strainer from the spray gun and place it on one of the tines of the lid support fork. Then place the spray gun upside down on the paint channel nozzle **without pulling the trigger**.
3. Now the gun is inverted. **Pull back the trigger** and dip it with the trigger clamp. Keep trigger clamp always in cleaning chamber.



This ensures that the paint channel is opened for cleaning and remaining paint can drain from cup connection socket.



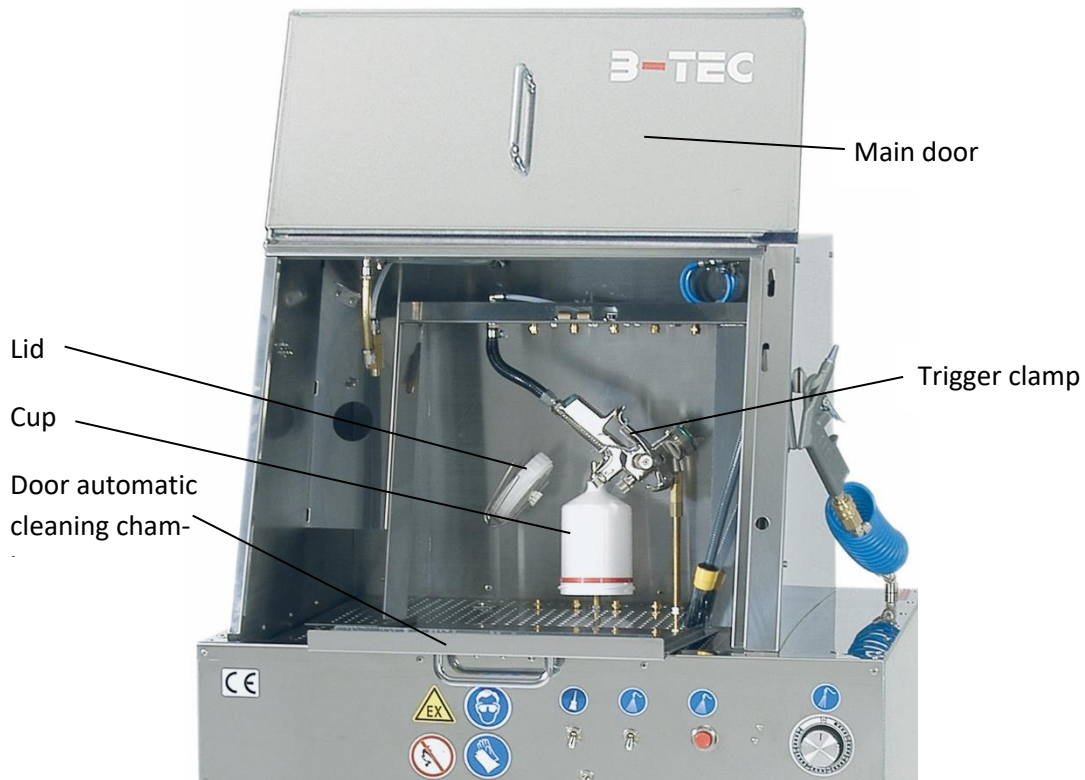

Figure 9-1

4. Connect black hose for air flushing to the spray gun. Ensure that the set screw on the gun is in the "opened" position to allow air flow.



This ensures that the air channels of the spray gun are pressurised during the cleaning process and therefore cleaning fluid and paints cannot enter the air channels or the air cap.

The spray gun is now positioned properly.

5. Close door of automatic cleaning chamber and the main door.



**Do not allow the doors to slam shut! All doors must be handled carefully and with caution by the user!**

6. Set timer to 1-3 minutes. The main cleaning cycle is activated. Cleaning fluid is drawn from the 60 litre container and circulates. The timer can be reset to zero by hand to stop the cleaning cycle. When the set time is over, open the door slowly and check the cleaning result.

**Main cleaning cycle**



**Do not open the door of automatic cleaning chamber while automatic cleaning cycle is running! If necessary, turn the timer to "0".**

7. Since the cleaning fluid is circulated while the timer is on, it will have a fair amount of contamination after a certain period of time. If a grey film remains on the spray gun after the main cleaning cycle, the automatic rinsing with fresh cleaning fluid can be used.
8. For automatic clean rinsing, close the door again and press and hold the rinse button (red button) for 3-4 seconds. Fresh cleaning fluid is drawn from the 30 litre drum. The spray gun is rinsed from inside and outside with fresh cleaning fluid.
9. Open the door of the automatic cleaning chamber and dry the spray gun, cup and lid by using the blow-off gun.
10. The spray gun is now clean. Depending on the cleaning fluid used, rinse spray gun with water, dry it, reassemble and bring back into action.



Clean the spray gun as soon as possible after all painting processes.



Before placing the spray gun in the machine, unscrew the lid from the cup and drain the remaining paint into a collecting container. For example the B-TEC collecting container for waste paint RST-01. The more thoroughly the cup is emptied, the longer the solvent or cleaner can be used.

Following these process steps and hints will ensure an optimal cleaning result!

Note:



**The brush has to be used only as intended for brushing parts. Never point the brush towards persons or pull outside of the machine.**



**Avoid dry runs of the pumps.**



**Do not open the door of automatic cleaning chamber while automatic cleaning cycle is running! If necessary, turn the timer to "0".**

## 9.2. Adjusting Options

Near the pumps are colour-coded flow adjusters for the following adjusting options:

- Green: Brush
- Red: Automatic cleaning
- Blue: Automatic clean rinse
- Black: Clean rinse nozzle

To adjust the air flow to the black air flushing hose, use the flow adjuster in the black hose located past the "T-plug" connector which is directly connected to the red hose for the automatic cleaning cycle.

Refer to pneumatic diagram section 4.3.

## 10. Care and Maintenance



**The machine has to be disconnected from the compressed air supply before any repair work! Wiping with a cloth only with sufficient moisture/wetness!**

- We recommend regular wet cleaning of intake hoses and intake strainers (at least each time the cleaning fluid is changed). If the intake strainer is defective, it must be replaced immediately. Defective intake strainers either have heavy paint build-up, causing clogging of the filter surface, or the filter suffer damage that allows contaminated cleaning fluid to be drawn in to the pump, which can damage it or clog the cleaning nozzles.
- Clean the perforated stainless steel grille and the interior walls of the machine regularly. Clean any residue out of the drain pan, in order to ensure reliable drainage of the cleaning agent / solvent and to ensure that there is permanent sufficient flow capacity in the drain.
- It is recommended to use each function of the machine shortly at least once a day in order to avoid drying of the membranes inside the pumps and keeping the nozzles clean.
- **When the machine is not operated for a longer period of time (for example during holidays) a cleaning cycle with fresh cleaning fluid should be performed after the final cleaning cycle so that the nozzles are not clogged with heavily contaminated cleaning fluid.**



The warranty is invalidated, if other than original B-TEC replacement parts are used!

Customer service: Contact your dealer or directly: B-TEC GmbH  
Zunftweg 6-8  
31303 Burgdorf / Ehlershausen  
Germany  
Tel.: +49(0)5085-97100-0  
Fax: +49(0)5085-97100-30  
Email: [info@btecsystems.de](mailto:info@btecsystems.de)  
[www.btecsystems.de](http://www.btecsystems.de)

## 11. Disposal

- If the machine shall be disposed of, please contact B-TEC or your dealer and request an appropriate quotation or the requirements for proper disposal.
- The machine must not be disposed of as domestic waste, but should be disposed of as hazardous waste depending on the degree of soiling. Contact your local authority for support.

## 12. Troubleshooting

### Cleaning cycle doesn't start / No cleaning fluid coming from the nozzles

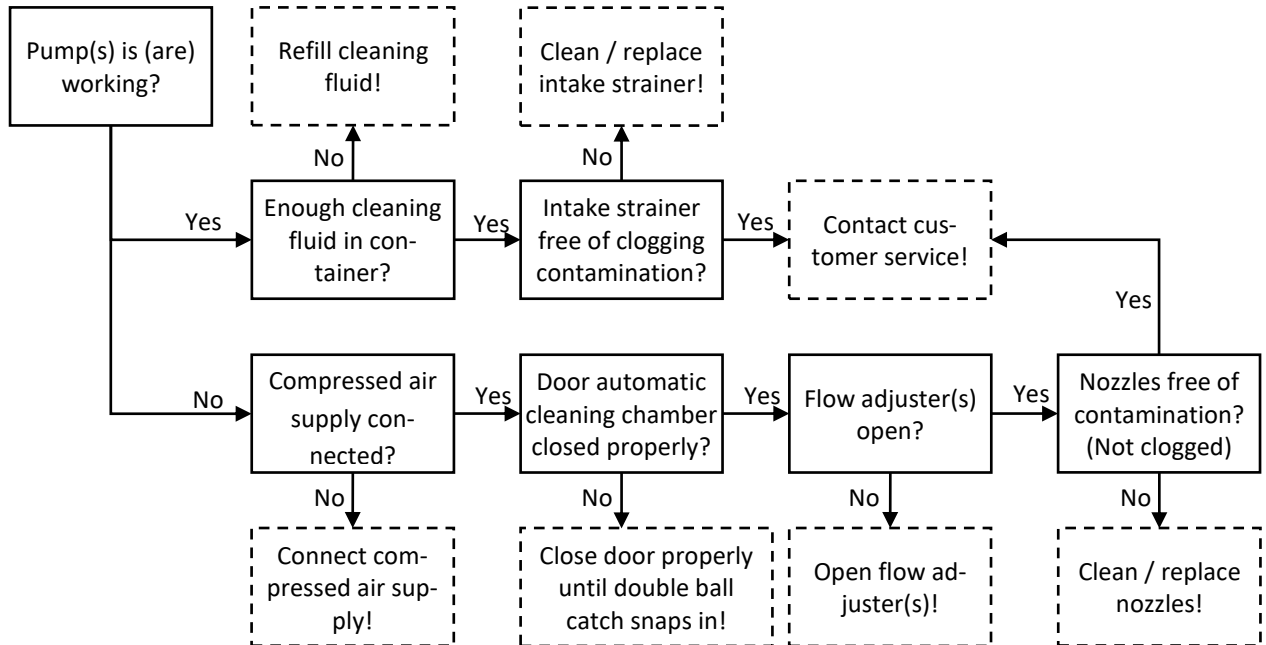

### Spray gun not cleaned properly

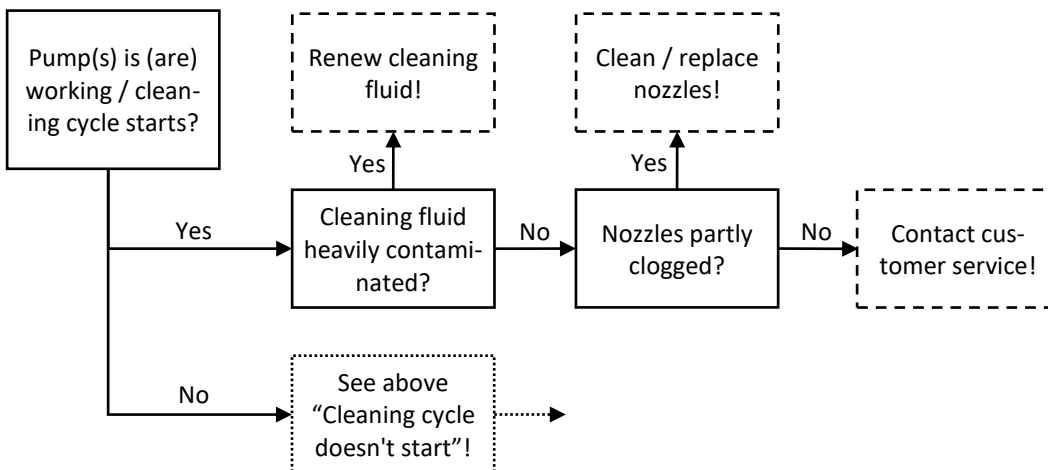

### 13. Safety Inspection Checklist

**Please make copies before filling out for the first time!**

**Safety inspections must be carried out at least once a year! Audit according to the applicable document regarding European Council Directive 2009/104/EC in the respective country.**

Model: \_\_\_\_\_  
 Serial no.: \_\_\_\_\_  
 Year of construction: \_\_\_\_\_  
 Place of Operation: \_\_\_\_\_

<u>Item checked</u>	<u>OK</u>	<u>Missing or faulty</u>	<u>Recheck</u>
1. Operating manual / Instruction available	<input type="checkbox"/>	<input type="checkbox"/>	<input type="checkbox"/>
2. Type plate	<input type="checkbox"/>	<input type="checkbox"/>	<input type="checkbox"/>
3. Warning signs	<input type="checkbox"/>	<input type="checkbox"/>	<input type="checkbox"/>
4. Condition of fluid hoses*	<input type="checkbox"/>	<input type="checkbox"/>	<input type="checkbox"/>
5. Condition of air hoses*	<input type="checkbox"/>	<input type="checkbox"/>	<input type="checkbox"/>
6. Clean intake strainer	<input type="checkbox"/>	<input type="checkbox"/>	<input type="checkbox"/>
7. Check cleaner cabinet for leaks	<input type="checkbox"/>	<input type="checkbox"/>	<input type="checkbox"/>
8. Function test all control elements	<input type="checkbox"/>	<input type="checkbox"/>	<input type="checkbox"/>
9. Grounding / Earthing	<input type="checkbox"/>	<input type="checkbox"/>	<input type="checkbox"/>
10. Function test of exhaust system	<input type="checkbox"/>	<input type="checkbox"/>	<input type="checkbox"/>
11. Function test roller valves	<input type="checkbox"/>	<input type="checkbox"/>	<input type="checkbox"/>

\* Check for brittleness, tight connections, etc.

#### Result of the safety inspection

- No faults, can be operated without restrictions.
- Restricted operation, faults to be fixed by date \_\_\_\_\_.
- Operation not permitted. Re-inspection necessary.

\_\_\_\_\_  
Date, place, signature of expert technician

\_\_\_\_\_  
Signature of operator